

Trapezoid Roof with Back Tray

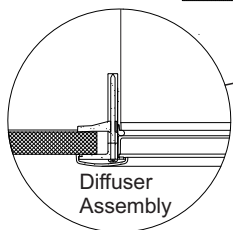
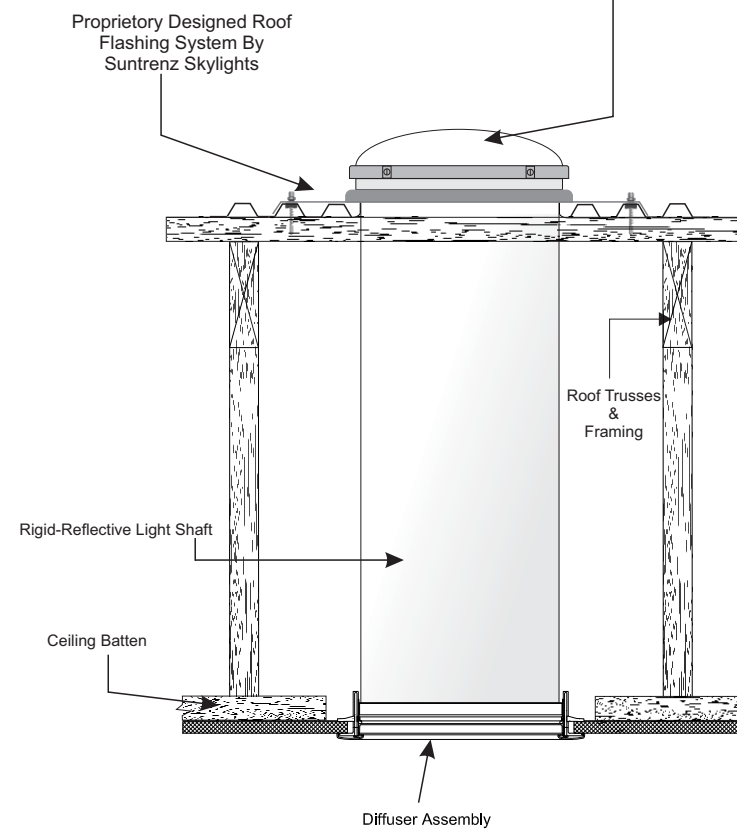
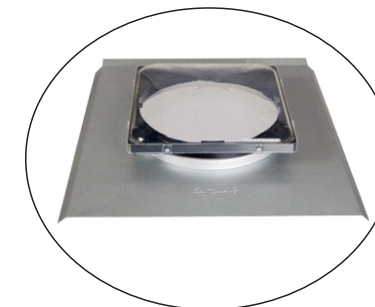
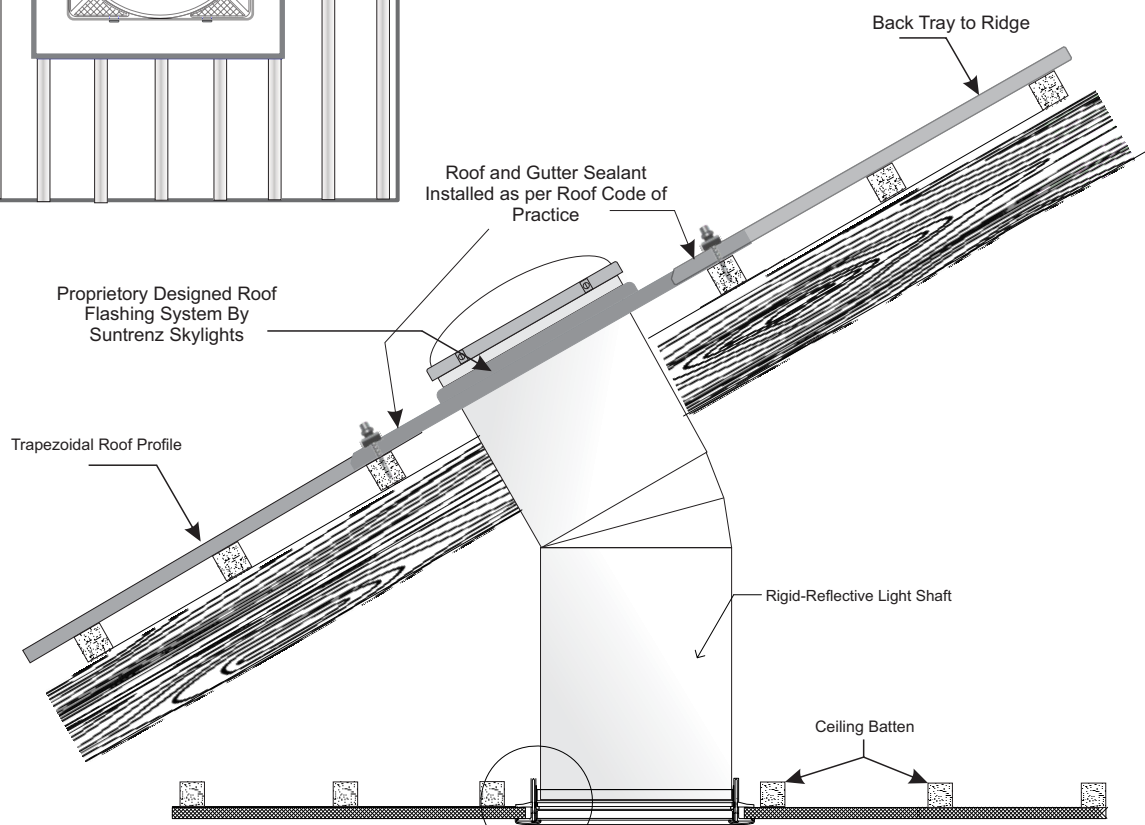
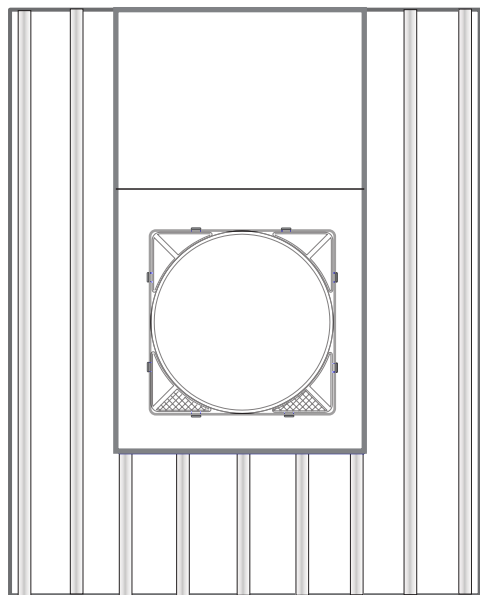

| | | |
|----------------|-------------------------|---|
| | Designed in New Zealand | |
| | | Ph: 0508 777 222 Email: sales@solarinnovations.co.nz |
| Trapezoid Roof | | Suntube: Trapezoid Roof with Back Tray |

| | Name | Date |
|-------------|------|--------|
| Drawn by | KB | Sep-21 |
| Checked by | KB | Sep-21 |
| Drawing No. | | |

Suntube with Rigid98

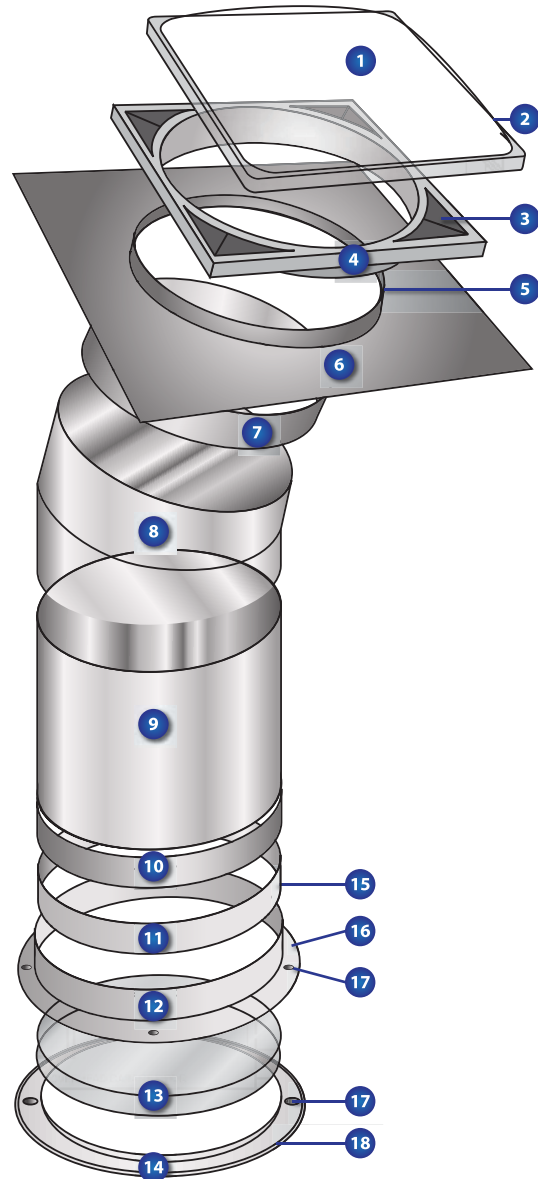

- 1) **DOMES** – U.V. Stabilized Grade 1 Acrylic (Altuglas – HF17) or Specialised UV Grade Polycarbonate (Sabic SLX)
- 2) **SCREWS x 8** – to fasten Dome (Class 3 corrosion resistant).
- 3) **VENT/SOLID TABS** – ASA Polymer (Luran S 778 T).
- 4) **BREATHER FRAME** – ASA Polymer (Luran S 778 T).
- 5) **SEAL** – Construction Grade Polyurethane (Bostik Seal’N’Flex 1).
- 6) **SOAKER TRAY** – 0.55mm Corrosion Resistant Steel (Colorbond).
- 7) **UPPER RING** – Rigid98 (Miro Silver).
- 8) **ANGLE ADAPTOR: upto 45° or 90°** – Rigid98 (Miro Silver).
- 9) **RIGID LENGTHS: 625mm or 1250mm** – Rigid98 (Miro Silver).
- 10) **LOWER RING** – Rigid98 (Miro Silver).
- 11) **LOCKING RING** – White ABS Thermoplastic (BASF GP22).
- 12) **CEILING FRAME** – White ABS Thermoplastic (BASF GP22).
- 13) **DIFFUSERS x 2** – 3mm PMMA (Acrylic) with Seadrift texture.
- 14) **DIFFUSER HOLDER** – White ABS Thermoplastic (BASF GP22).
- 15) **SCREWS** – to retain Flexi-tube Locking Ring to Ceiling Frame.
- 16) **SCREWS** – to fasten Ceiling Frame, includes lock lug and cover cap.
- 17) **MAGNET** – N45 Grade / Rare Earth (Neodymium Iron Boron).
- 18) **FOAM SEAL** – 3mm x 6mm Foam.
- 19) **REFLECTIVE RING** – 0.45mm 430BA Stainless Steel.
- 20) **TAPE** – PVC Duct Tape (TESA 4050).
- 21) **FLEXI-TUBE** – Composite 3 layers including metalized polyester, aluminium foil and spring wire.

Suntube with Flexi-Tube

